

Zinkovskiy Yu. F.¹, Sydoruk Yu. K.², Turovskiy A. O.³¹Doctor of science, Professor, National technical university of Ukraine «Kyiv polytechnic institute», Ukraine²Associate professor, National technical university of Ukraine «Kyiv polytechnic institute», Ukraine, E-mail: sydoruk_@ukr.net³Assistant, National technical university of Ukraine «Kyiv polytechnic institute», Ukraine, E-mail: toljatyr@i.ua

ELECTRIC FIELD HOMOGENEITY PROBLEM IN THE MULTI-ELECTRODE PHASE-ADJUSTABLE APPLICATOR

In our study we have proposed a mathematical model of multiphase cylindrical apparatus for bulk materials treatment with radio frequency electric field. According to the model the analysis of the distribution of the electric field inside the zone restricted with multiple connected circular arc-shaped boundary on the basis of the field coupling problem of the theory of singular integral equations is performed. The expressions for determination of the electric field strength in the core are given. Also we propose a schematic diagram of the generator for the electrodes excitation and the principle of building of the apparatus for treatment of grain and other bulk materials with the electric field of radio frequency.

Keywords: electric field, high frequency, integral singular equations, homogeneity, applicator.

INTRODUCTION

The electrical technologies have been implemented in the various areas of industry. The agricultural complex has also benefited from the said technologies. Scientific and technical achievements created the opportunity to improve the technologies for production and storage of crops. Such the innovations include the use of radio frequency (RF) electric field and microwave electromagnetic field for pre-sawing treatment of seeds, drying and disinfection of grain, berries as well as for many others instances.

During the pre-sawing treatment of seeds with electric and electromagnetic fields the growth activation is also accompanied with extermination of pathogenic organisms and pests. Seeds irradiated with the electromagnetic field grow faster, develop much better and acquire higher resistance to diseases and natural disasters [1, 2]. Grain drying with the help of electric and electromagnetic fields also offers a series of advantages. In particular, it is possible to reduce energy costs, perform drying under low air pressure which intensifies evaporation at relatively low temperatures to ensure high homogeneity of heating. All of the above provide significantly higher grain quality and reduce its losses during storage.

MATERIAL AND METHODS

Equally distributed heating of the entire bulk of grain is one of the prominent technological features of the hardware, implemented for drying and disinfection of grain. Within the interaction zone where the energy is delivered via the electric field, the latter must be substantially homogeneous.

In RF apparatuses for drying and disinfection of grain the electric field strength in the interaction zone is of great importance and should not be less than 1,2–1,8 kV/cm. For

instance, if the distance between the electrodes $d = 30$ cm, the voltage on the electrodes should be 36–54 kV. Thus, RF dryers require generators with high output voltage, and this creates difficulties for their designing and operation.

When creating and designing RF systems it is also necessary to take into account the fact that the load on the generator is predominantly of capacitive character, and significant increase of the capacity causes difficulty in matching of the electrodes with the generators thus affecting the efficiency.

ENSURING OF UNIFORMITY OF THE ELECTRIC FIELD IN THE IRRADIATION AREA

A simple implementation of an electrode system, which can provide a homogeneous electric field has two parallel metal plates. To reduce the influence of edge effects and to ensure the uniformity of the field it is necessary to increase the size of the electrodes, but it will cause significant increase of their capacity.

The proposed electrode structure can be characterized by the high level of homogeneity of electric field in the interaction zone, high energy efficiency and significantly lower capacity compared to plain electrodes with the same productivity.

In order to obtain the high homogeneity of the electric field with a smaller capacity compared to the planar electrodes, ensuring high performance of the apparatus, the use of the electrode structure [5] is proposed. The structure consists of n arc-shaped electrodes placed on the side of a cylinder of radius r and length l , where $l \gg r$. It is assumed that the electrodes are perfectly conductive and are of negligibly small thickness, and the whole structure is surrounded with vacuum. The potential of each electrode is $V_{01}, V_{02}, \dots, V_{0n}$, respectively.

The objective of this research is to provide a mathematical model of the structure described in order of its implementation as a part of an apparatus for processing of dielectric bulk materials with RF electric field. Thus it is necessary to determine the distribution of the electric field in the region inside the electrodes structure, which then specify the optimal number and sizes of the electrodes to provide the required size of the interaction area. Herewith the area of interaction is to be located within the field homogeneity region.

THEORETICAL ANALYSIS OF THE ELECTRIC FIELD IN MULTIPLE-ELECTRODE STRUCTURE

Since $l \gg r$ the problem of calculation of the potential and strength of the electric field within the cylinder is reduced to a plane problem in an infinite complex plane with a ring-shaped n -electrode boundary L of radius r . Ring-shaped boundary L is divided into separate segments of disconnected arcs $L_1, L_2, \dots, L_n \subset L$, which have no common points (Fig. 1). Arcs L_1, L_2, \dots, L_n , located in the intervals $a_1 b_1, a_2 b_2, a_3 b_3, \dots, a_n b_n$, are equipotential because of being perfectly conductive. The potential of each arc, respectively, equals $V_{01}, V_{02}, \dots, V_{0n}$. With respect to a circle of radius r full complex plane z is divided into two symmetrical sections: external S_+ , for which $|z| \geq r$, and internal S_- , for which $|z| \leq r$, where z is an independent complex variable. The problem is to determine the complex potential $\Phi(z) = U(z) + jV(z)$, where $V(z)$ is a potential of the field, and the electric field $\bar{E}(z) = -j[\Phi'(z)]^*$ [3], where $\Phi'(z)$ is the derivative of the potential with respect to z . Electric field strength $\bar{E}(z)$ is a single-valued analytic function, and a sign $[\dots]^*$ stands for a complex conjugation. These functions are specified at every point within the complex plane z [4]. All over the complex plane function $\bar{E}(z)$ possess the following properties:

1. $\bar{E}(z)$ is limited in value everywhere except the arcs' ends (points a_k and b_k), at which $\bar{E}(z) \rightarrow \infty$.
2. Due to the symmetry of with respect to the boundary circle on arcs $a_k b_k$ and on arcs $b_k a_{k+1}$, where is the electric field at the boundary arcs on the outside and is the electric

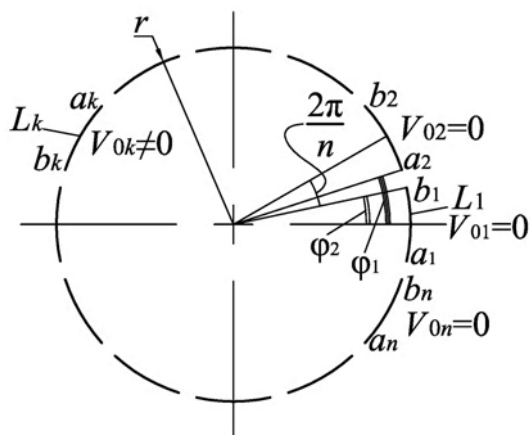

Fig. 1. Arrangement of electrodes of the structure

field on the inside of the circle, denotes the complex coordinate on the boundary.

3. On arcs $a_k b_k$ tangential component of the electric field $\bar{E}_\tau(\gamma)$ with respect to the boundary circle takes zero value, and on arcs $b_k a_{k+1}$ the perpendicular component of the electric field is equal to zero both on the external and on the internal side of the arcs.

4. At infinity $\bar{E}(z)$ has a zero of second order.

5. With respect to the boundary circle the electric field and the complex potential are related by the equations

$$\bar{E}(z)_{S_+} = \left(\bar{E} \left(\frac{1}{z^*} \right) / z^{*2} \right)_{S_-}^* \text{ and } \Phi(z) = - \left(\Phi \left(\frac{1}{z^*} \right) \right)^*$$

where S_+ and S_- denote the external and internal sides of the boundary, respectively.

According to the properties referred to above, $\bar{E}(z)$ is a piecewise holomorphic function and L denotes a set of finite number of simple (smooth) arcs ($L_1, L_2, \dots, L_n \in L$), which have no common points, in addition the electric field $\bar{E}^+(\gamma)$ at L obeys the expression: $\bar{E}^+(\gamma) = G(\gamma)\bar{E}^-(\gamma)$.

Due to the property 2 the function $G(\gamma)$ is equal to -1 at arcs $a_k b_k$ and is equal to 1 at $b_k a_{k+1}$, i.e. is piecewise constant function with the discontinuity of the first kind when going through the points a_k and b_k . So points a_k and b_k are nodal and singular, and is constant all over on the L except nodes.

The above properties of $\bar{E}(z)$ fit the field coupling problem of the theory of singular integral equations [5].

A general form of the expression of homogeneous problem of field coupling in the case when the function to be found (the electric field) is finite can be written at infinity as follows [5]:

$$F(\xi) = X(\xi)P(\xi), \tag{1}$$

where $F(\xi)$ is the function to be found, $X(\xi)$ is some canonical solution, $P(\xi)$ is arbitrary polynomial of power k , ξ is independent complex variable.

With respect to the problem, expression (1) takes the form:

$$E(z) = X(z^*)P(z^*). \tag{2}$$

Following the above theory the power of the polynomial $P(z^*)$ and the so-called index of the problem of coupling χ is determined by the behavior of $E(z)$ at infinity.

Since $E(z)$ has at infinity a zero of the second order, $P(z)$ is of power m , so the power of $X(z)$ is equal to $\chi = (m + 2)$. According to definition [3]:

$$\chi = [\arg G(\gamma)]_L / 2\pi,$$

where the sign $[\dots]_L$ denotes the increment of expression enclosed in parentheses when passing the contour L once in a positive direction. Due to the fact that a_k and b_k are

singular nodes $[\arg G(\gamma)]_L = 2\pi n$, $\chi = n$, $m = n - 2$. With the known index of the problem of coupling the polynomial expression will take the form

$$P(z^*) = \sum_{k=2}^n C_{k-1} (z^*)^{n-k}. \quad (3)$$

The class of the problem is determined depending on the behavior of $G(\gamma)$ and $F(z)$ in nodes. Accordingly, the nodes are singular when $F(z)$ at nodes is infinite, and non-singular, when the function in the nodes is limited. Conventionally, the class of the problem is denoted by h_i , where i is the number of non-singular nodes at the boundary line.

Thus, in general, the problem of class h_q has the canonical function:

$$X(\xi) = Q \frac{\sqrt{R_1(\xi)}}{\sqrt{R_2(\xi)}}, \quad (4)$$

where Q is an arbitrary constant and

$$R_1(\xi) = \prod_{k=1}^q (\xi - c_k), \quad (5 a)$$

$$R_2(\xi) = \prod_{k=q+1}^{2n} (\xi - c_k), \quad (5 b)$$

where c_1, c_2, \dots, c_q are non-singular nodes; $c_{q+1}, c_{q+2}, \dots, c_{2n}$ are singular nodes. The discussed problem has no non-singular nodes, therefore $q = 0$ and the problem is characterized as a problem of class h_0 , and its canonical function is

$$X(z^*) = \frac{Q}{\sqrt{R(z^*)}}, \quad (6)$$

where $R(z^*) = \prod_{k=1}^n (z^* - a_k)(z^* - b_k)$ and constant Q can be obtained according to the property 3 on the boundary

circle from the expression $Q = 4 \sqrt{\prod_{k=1}^n a_k b_k}$ [4].

In what follows the expressions of the electric field and potential, it is advisable, to be represented in the form of normalized variable $Z = z/r$, which is achieved by conformal mapping of the complex plane z onto the plane of a single boundary circle Z . Using expressions (2, 3, 5, 6) and

performing the procedure of conformal mapping we obtain the expression of the electric field

$$E(Z^*) = \frac{4 \sqrt{\prod_{k=1}^n a_k b_k} \sum_{k=2}^n C_{k-1} (Z^*)^{n-k}}{r \sqrt{\prod_{k=1}^n (Z^* - a_k)(Z^* - b_k)}}, \quad (7)$$

and potential

$$V = -\operatorname{Re} \left[\frac{4 \sqrt{\prod_{k=1}^n a_k b_k} \sum_{k=2}^n C_{k-1} (Z^*)^{n-k} dZ^*}{R \int_z \sqrt{\prod_{k=1}^n (Z^* - a_k)(Z^* - b_k)}} \right]^*. \quad (8)$$

The two expressions above can be used as initial for calculating the electric field and potential at each point in the region Z for arbitrary distribution of the points a_k and b_k within the boundary circle L as well as for random distribution of potential on the boundary arcs L_k . According to the statement of the problem it is necessary to create uniform distribution of electric field within the electrode structure, which is only possible when $L_1 = L_2 = L_3 = \dots = L_m$ and $b_1 a_2 = b_2 a_3 = \dots = b_n a_1$. Let $2\varphi_1$ denotes the angle by which all the arcs are bent down, respectively, the angular interval between the adjacent arcs is denoted by $2\varphi_2$, the angular distance between the midpoints of adjacent arcs is $2\pi/n$ (Fig. 1). Assuming the linearity of dielectric properties of treated medium the total electric field and potential within the given structure with an arbitrary distribution of the voltages among the arcs can be found as the sum of strengths and potentials obtained from the partial solution of the problem where only one arc L_k possesses potential V_{0k} and the others arcs are of zero potential. With regard to these conditions, the expression of the electric field (7) can be written as follows:

$$E(Z^*) = \frac{1}{r} \frac{\sum_{k=2}^n C_{k-1} (Z^*)^{n-k}}{\sqrt{Z^{*2n} - 2Z^{*n} \cos n\varphi_1 + 1}}, \quad (9)$$

and the electric field lines pattern is depicted in Fig. 2. The electric field structure is symmetric with respect to line u , which passes through the center of arc L_k , which possesses potential V_{0k} (Fig. 2), therefore the symmetric coefficients must be equal to each other: $C_1 = C_{n-1}$, $C_2 = C_{n-2}$... Hence the number of unknown coefficients is reduced to $N = n/2$ for even n and to $N = (n + 1)/2$ for odd values of n .

After performing the boundary conditions symmetrization with respect to the u -axis, the equation (9) takes the form:

$$\dot{E}(Z)_k = \frac{(-1)^{k-1}}{r} Z^{*\frac{n-1}{2}} \times \sum_{i=1}^N C_i \left\{ Z^{*\frac{n-i}{2}} \exp \left[j \left(\frac{n-i}{2} \right) \frac{2\pi}{n} (k-1) \right] + Z^{*i-\frac{n}{2}} \exp \left[-j \left(\frac{n-i}{2} \right) \frac{2\pi}{n} (k-1) \right] \right\} \times \frac{1}{\sqrt{Z^{*2n} - 2Z^{*n} \cos n\varphi_1 + 1}} \quad (10)$$

Taking into account that the distance from all the points on the boundary circle to the origin equals r , in order to describe location of any point on the circle, it is sufficient to specify only the angular coordinate φ , which corresponds to a polar coordinate system.

Hence on boundary circle we have $Z = \exp(j\varphi)$. Substituting the value of Z in (10) and using Euler transformation, we obtain the expression for electric field strength on the boundary circle:

$$E(Z)_\varphi^k = \sqrt{2} \frac{(-1)^{k-1}}{r} \sum_{i=1}^N C_i \cos(n/2 - i) \left[\varphi - \frac{2\pi}{n} (k-1) \right] \frac{1}{\sqrt{\cos n\varphi - \cos n\varphi_1}} e^{-j2\varphi} \quad (11)$$

Expression (11) is used to determine the unknown coefficients C_i by integrating $E_\varphi(Z)_k$ between the nodes b_k and a_{k+1} , whose difference of potential is known. As the number of the intervals is equal to N , the number of the linear independent equations, wherefrom the N unknown coefficients C_i are defined, is also equal to N . The N -order set when applying the potential V_{0k} to the k -th arc is written as

$$\sum_{i=1}^N C_i \sin \left(i \frac{\pi}{n} (2p-1) \right) P_{-i/n}(\cos n\varphi_2) = \frac{nV_{b_{k+p-1}a_{k+p}}}{2\pi} \quad (12)$$

where $P_{-i/n}(\cos(n\varphi_2))$ is a Legendre function of order $(-i/n)$, p denotes the number of equation ($p \in [1, 2, \dots, N]$), $V_{b_{k+p-1}a_{k+p}}$

is the difference of potential between the points b_{k+p-1} and a_{k+p} . In this set only the first equation, for which $p=1$, has a right-hand side ($V_{0k} \neq 0$), in other equations for which $p > 1$, the right side is zero. A more detailed mathematical explanation of the given expressions has been provided in [6, 7].

The high degree of homogeneity of the electric field within the inside region z and rotation of field can be obtained if the potential distribution on the boundary arcs is provided according to the expression:

$$V_{0k} = V_{0m} \sin[\omega t + (k-1)2\pi/n], \quad (13)$$

where ω and V_{0m} represent the cyclic frequency and amplitude of the electrodes supply signal, accordingly, t is time. Thus the total vector of the electric field will be oriented between the electrodes with the maximum instantaneous voltage, phase of signal at which is equal to $\pi/2 + \pi M$, where M is arbitrary integer.

Since $C_i = V_{0k} F_i$, and $F_i = -(n/2\pi) \frac{1}{A} (1/P_{-i/n}(\cos n\varphi_2))$, where A is the determinant of the set (12) and A_i is the algebraic complement of its i -th element [7], so the expression (10), after (13) being substituted in it, and finding the total field generated by all the arcs by calculating the corresponding sum by k , takes the form:

$$E(Z)_n = \frac{n V_{0m}}{2 r} F_1 \left[\frac{\sin \omega t (1 + Z^{*(n-2)}) + j \cos \omega t (1 - Z^{*(n-2)})}{\sqrt{Z^{*2n} - 2Z^{*n} \cos n\varphi_2 + 1}} \right] \quad (14)$$

RESULTS AND DISCUSSIONS

Calculation of the electric field according to equation (14) shows that for small values of n the electric field in the inner region of complex plane z is considerably inhomogeneous, but there is a rise in homogeneity when n increases. To illustrate this statement in Fig. 3 and Fig. 4 the graphical results of calculations of $|E(z)|$ for $n=4$, $n=8$ and $\varphi_2 = \pi/2n$ are presented. Here in the figures it is assumed that $z = x + jy$, where x and y are the coordinates normalized to the radius r and all the values are normalized to the value in the center. It is apparent that for $n=8$ the radius of homogeneity zone r_h is equal to 60 % of the boundary circle radius.

At the same time for $n=4$ the size of uniformity zone is virtually absent. The size of the uniformity zone also depends on the angle $2\varphi_2$. For small values of n the effect of this parameter on the homogeneity of the field is

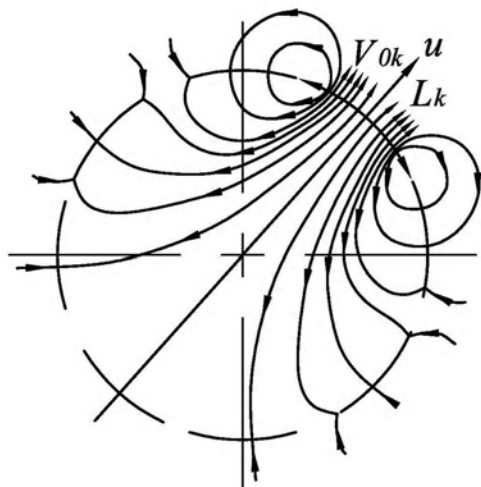
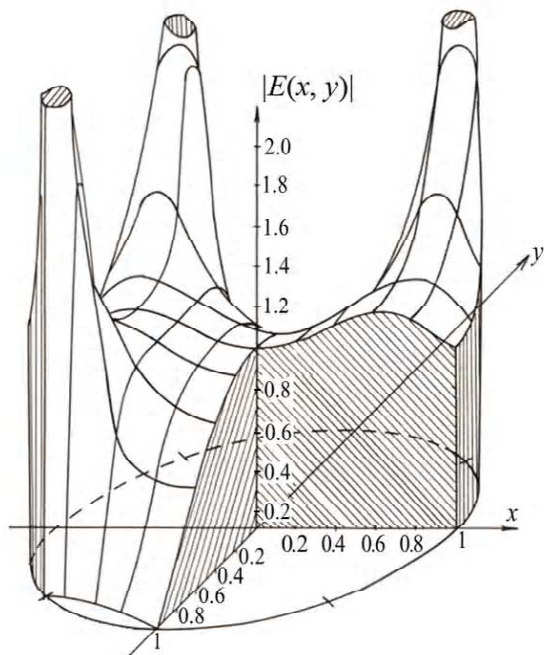
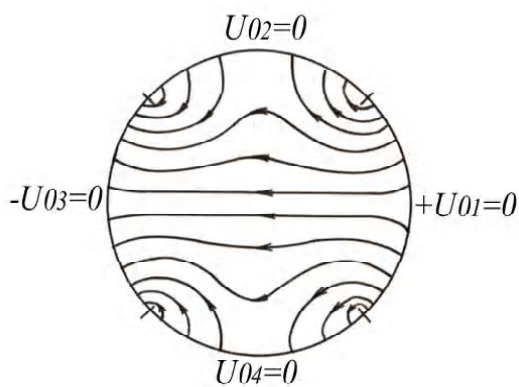

Fig. 2. Structure of the electric field lines



a)



b)

Fig. 3. Dependence of $|E(x, y)|$ (a) and the electric field lines pattern (b) for $n = 4$

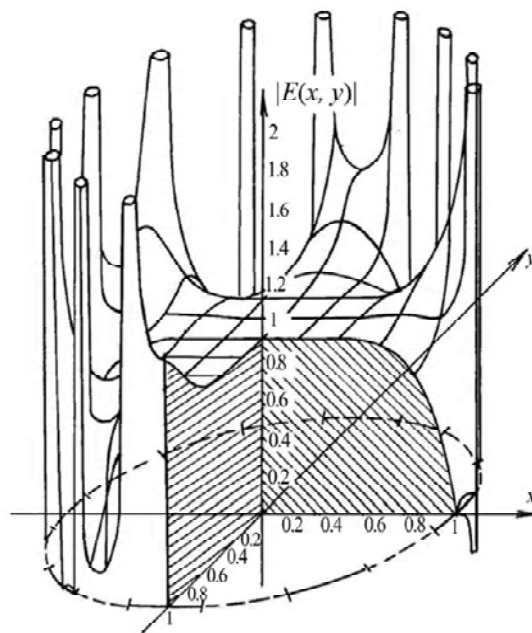

a)

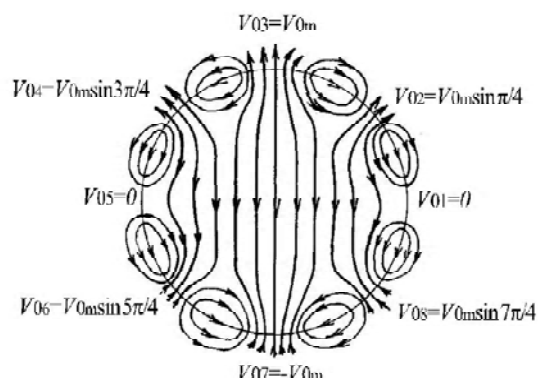

b)

Fig. 4. Dependence of $|E(x, y)|$ (a) and the electric field lines pattern (b) for $n = 8$

significant, but with the increase of n the effect on the zone size decreases. A major advantage of this electrode structure is the fact that the electric field in the zone of homogeneity has rotational character. This feature also improves the uniformity of the irradiation facility, especially in the cases when the individual particles to be irradiated are of elongated shape.

THE PRINCIPLES OF CONSTRUCTION OF THE APPARATUS FOR TREATMENT OF GRAIN WITH RADIO FREQUENCY ELECTRIC FIELD

The base of the device is an electrode system formed on the side of a cylindrical chamber through which the treated bulk material passes. The electrodes are made in the form of thin metal strips of arc-shaped cross section and are embedded

in dielectrical shell 1 and 3 (Fig. 5) [9]. The dielectrical shell 1 inside of which the grain or other bulk material is processed is oriented vertically so that it moved by gravity. All the electrodes are of the same size and the angle between the midpoints of the adjacent electrodes is $2\pi/n$. From the outside the electrode system is shielded with metal screen 4.

Multiphase (n -phase) generator that feeds the electrode system has n output units, which are located around the electrode system. Each unit is placed closely to the fed electrode in separate chamber 5. Electrodes are interconnected with the generator unit with a cable 6. Material to be processed 7, contained in the input container 8, is gravity fed through the interaction zone to the output tank 9. The velocity of the material and, accordingly, processing time is adjustable with sliding diaphragm 10.

Generator, whose block diagram is shown in Fig. 6, *a*, forms a monochromatic signal in the frequency range from 10 to 100 MHz. It includes the tunable oscillator with an amplifier 1; signal replicator 2, which has four outputs of equal signals amplitudes and phases differed by 90° ; signal replicator 3, which has four inputs and 8 outputs with phase difference between adjacent outputs equal to $\pi/4$; amplifiers and high-voltage transformers 4^I-4^{IV} . In Fig. 6, *b* the layout of the electrodes connection is shown, whose numbers correspond to the numbers of the generator outputs. For each output the phase shift of the signal is also given. The generator also incorporates a system for monitoring and correcting the amplitudes and phases of the output signals that is not stated in the figure.

CONCLUSIONS

The problem of field coupling of the theory of singular integral equations is an effective tool for analyzing the distribution of the electric field inside the space bounded by multiply connected circular arc-shaped boundary, and allows us to obtain precise analytical expressions for the electric field distribution within the electrode structure. The calculations showed that the size of the zone of uniform field distribution inside the structure is determined by the phase and amplitude distribution on each electrode. When excited the regularly placed electrodes with a harmonic voltage with relative phase shift corresponded to the angular position of the electrode on the circle, with a number of elements of structure equal to 8 the size of uniformity zone is 60 % of the diameter of the structure. Thus excited the electrode structure provides the uniform rotation of the field.

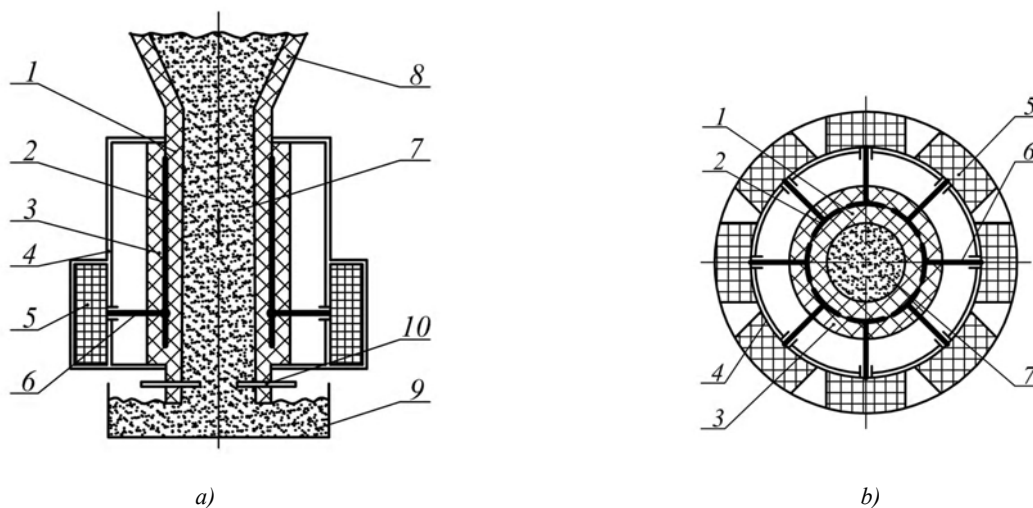

Fig. 5. Embodiment of the device for treating of grain with radio frequency electric field given in the vertical (*a*) and horizontal section (*b*)

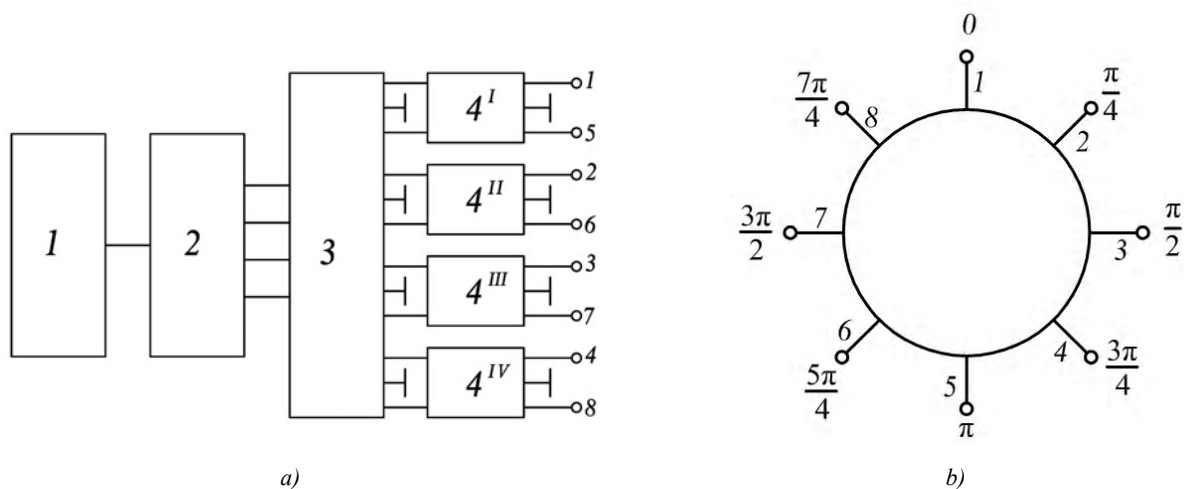

Fig. 6. Schematic diagram of the feeding generator (*a*) and of electrodes allocation scheme (*b*)

REFERENCES

1. *Rajagopal, V.* Disinfestation of stored grain insects using microwave energy: a thesis... of doctor of philosophy / V. Rajagopal. – Manitoba, 2009. – 197 p.
2. *Nelson, S. O.* Review and assessment of radio-frequency and microwave energy for stored-grain insect control // *Trans. of the ASAE.* – 1996. – Vol. 39, No.4. – pp. 1475–1484.
3. *Лаврентьев, М. А.* Методы теории функций комплексного переменного / М. А. Лаврентьев, Б. В. Шабат. – С.Пб.: Лань, 2002. – 688 с.
4. *Мусхелишвили, Н. И.* Сингулярные интегральные уравнения: Граничные задачи теории функций и некоторые их приложения к математической физике. – М.: Наука, 1968. – 512 с.
5. *Зиньковский, Ю. Ф.* Задача сопряжения в расчётах напряженности и потенциала электрического поля кольцевой многосвязной структуры / Ю. Ф. Зиньковский, Ю. К. Сидорук, А. В. Голощапов // *Изв. высш. уч. заведений. Радиоэлектроника.* – 2007. – Т. 50, № 5. – С. 76–80.
6. *Зиньковский, Ю. Ф.* Напряженность электрического поля в области с кольцевой многосвязной границей и равными длинами граничных дуг / Ю. Ф. Зиньковский, Ю. К. Сидорук, А. В. Голощапов // *Изв. высш. уч. заведений. Радиоэлектроника.* – 2009. – Т. 52, №2. – С. 14–22.
7. *Зиньковский, Ю. Ф.* Управляемое электрическое поле в многосвязной кольцевой структуре / Ю. Ф. Зиньковский, Ю. К. Сидорук // *Изв. высш. уч. заведений. Радиоэлектроника.* – 2012. – Т. 55, № 6. – С. 45–56.
8. Патент України 69812 А01С 1/00. Установка для сушіння зерна та інших сипучих матеріалів електромагнітним полем високої частоти / Сидорук Ю. К.; заяв 21.11.2011, опубл. 10.05.2012, Бюл. № 9, 2012 р.

Стаття надійшла до редакції 02.04.2013.

Зиньковский Ю. Ф.¹, Сидорук Ю. К.², Туровский А. О.³

¹Д-р техн. наук, профессор, Національний технічний університет України «Київський політехнічний інститут», Україна

²Доцент, Національний технічний університет України «Київський політехнічний інститут», Україна

³Асистент, Національний технічний університет України «Київський політехнічний інститут», Україна

ЗАДАЧА ОДНОРІДНОСТІ ЕЛЕКТРИЧНОГО ПОЛЯ У БАГАТОЕЛЕКТРОДНІЙ ФАЗОМАНІПУЛЬОВАНИЙ СТРУКТУРІ

Виконано аналіз розподілу напруженості електричного поля всередині простору, обмеженого багатозв'язною кільцевою границею на основі теорії інтегральних сингулярних рівнянь у вигляді задачі спряження. Наведено розрахункові формули для визначення напруженості електричного поля в активній зоні. Запропоновані структурна схема генератора для живлення електродів та принцип побудови установки для опромінення зерна та інших сипучих матеріалів електричним полем високої частоти.

Ключові слова: електричне поле, висока частота, інтегральні сингулярні рівняння, рівномірність.

Зиньковский Ю. Ф.¹, Сидорук Ю. К.², Туровский А. А.³

¹Д-р техн. наук, профессор, Национальный технический университет Украины «Киевский политехнический институт», Украина

²Доцент, Национальный технический университет Украины «Киевский политехнический институт», Украина

³Ассистент, Национальный технический университет Украины «Киевский политехнический институт», Украина

ЗАДАЧА ОДНОРОДНОСТИ ЭЛЕКТРИЧЕСКОГО ПОЛЯ В МНОГОЭЛЕКТРОДНОЙ ФАЗОМАНІПУЛЬОВАНИЙ СТРУКТУРЕ

Выполнен анализ распределения напряженности электрического поля внутри пространства, ограниченного многосвязной кольцевой границей на основе теории интегральных сингулярных уравнений в виде задачи сопряжения. Приведены расчетные формулы для определения напряженности электрического поля в активной зоне. Предложены структурная схема генератора для питания электродов и принцип построения установки для облучения зерна и других сыпучих материалов электрическим полем высокой частоты.

Ключевые слова: электрическое поле, высокая частота, интегральные сингулярные уравнения, равномерность.

REFERENCES

1. *Rajagopal V.* Disinfestation of stored grain insects using microwave energy, Ph. D. Thesis, University of Manitoba, Winnipeg, Canada, 2009, 197 p.
2. *Nelson S. O.* Review and assessment of radio-frequency and microwave energy for stored-grain insect control, *Transactions of the ASAE*, 1996, Vol. 39, No. 4, pp. 1475–1484.
3. *Lavrentev M. A., Shabat M. A.* *Metody teorii funkciy kompleksnogo peremennogo.* St. Petersburg, Lan, 2002, 699 p.
4. *Muskhelishvili N. I.* Singular integral equations. Boundary value problems of the theory of functions and some of their applications to mathematical physics, 3rd ed. Moscow, Nauka, 1968, 512 p.
5. *Zin'kovskii Yu. F., Sidoruk Yu. K. and Goloshchapov A. V.* The problem of conjugation in calculations of electric field strength and potential of a ring-shaped multiply connected structure, *Radioelectronics and Communications Systems*, 2007, Vol. 50, No. 5, pp. 284–287.
6. *Zin'kovskii Yu. F. and Yu. K. Sidoruk,* Electric field density in the region with circular multiply connected border and equal lengths of bounding arcs, *Radioelectronics and Communications Systems*, 2009, Vol. 52, No. 2, pp. 63–69.
7. *Zin'kovskii Yu. F. and Yu. K. Sidoruk,* Controlled electric field in multiply connected circular structure, *Radioelectronics and Communications Systems*, 2012, Vol. 55, No. 6, pp. 277–287.
8. *Sydoruk Yu. K.* Apparatus for drying grain and other bulk materials with high frequency electromagnetic field, Patent of Ukraine 65629, May 2011.